

and water fluxes, one concludes from these model studies that the water content should be less than 5% for  $F_{Ac} = 0.8$ , which according to Loeb<sup>14</sup> is a desirable degree of acetylation for membranes.

Since these conclusions on limits of acetylation and water content are deduced from activity coefficients at saturation, since  $\gamma_{\pm(0)}$  for these systems would increase with dilution, and since  $\gamma_{\pm(aq)}$ , which for NaCl at saturation is *ca.* 1, will decrease with salt concentration in an intermediate range, some relaxation of the limits seems reasonable. We have also ignored here the case of poor coupling between water and salt fluxes where differences in diffusion coefficients could increase the asymptotic rejection of salt beyond that expected from the distribution coefficients alone. However, it seems unlikely that these differences would be large enough as to invalidate the principal conclusion—namely, that the effectiveness of existing cellulose acetate membranes must be caused by an effective layer which has a low water content.

We speak of an "effective layer" of the membranes because it is now almost certain that the cellulose acetate membranes, as a whole, are too thick to yield permeability of the type normally observed and at the same time be homogeneous enough to reject salt well. This observation has been made independently during the past year at a number of laboratories. We might mention here the work by Merten and co-workers<sup>16</sup> which through electron microscopy showed existence of a thin, relatively homogeneous layer at the face of the membranes. It may be worthwhile here, however, to show that the same conclusion can be reached through analysis of the flux equations for water in a homogeneous membrane.

The diffusional flux of water  $J_1$  (moles  $\text{cm.}^{-1} \text{sec.}^{-1}$ ) through a membrane is described by

$$J_1 = \mathcal{D}_1 c_1 \nabla \mu_1 / RT \quad (3)$$

if the system does not contain other components which

(17) R. L. Riley, J. O. Gardner, and U. Merten, *Science*, **143**, 801 (1964).

can diffuse. In eq. 3,  $\mathcal{D}_1$  is diffusion coefficient ( $\text{cm.}^2 \text{sec.}^{-1}$ ),  $c_1$  is concentration of water in the medium (moles  $\text{cm.}^{-3}$ ),  $\mu_1$  is the chemical potential,  $R$  is the gas constant, and  $T$  is the absolute temperature. In a membrane system under pressure the chemical potential gradient of water (absence of salt) is given by

$$\nabla \mu_1 = V_1 \nabla p \quad (4)$$

where  $V_1$  is molar volume and  $p$  is pressure. Since  $c_1 = f_w \rho / M_1$ , where  $f_w$  is the fractional water content,  $\rho$  is density of the solution, and  $M_1$  the molecular weight of water

$$J_1 = \mathcal{D}_1 V_1 f_w \rho \nabla p / M_1 RT \quad (5)$$

For our system  $V_1 \rho / M_1 \approx 1$ . Hence, eq. 5 simplifies to

$$J_1 \approx f_w \mathcal{D}_1 \nabla p / RT \quad (5a)$$

For a membrane with thickness  $d$  of the homogeneous layer,  $\nabla p = \Delta p / d$  and hence

$$d \approx f_w \mathcal{D}_1 \Delta p / J_1 RT \quad (6)$$

For a Loeb-type membrane which at 25° and an applied pressure of 100 atm. has a flow rate of 15 gal./ft.<sup>2</sup>/day

$$d \approx 1 \times 10^2 f_w \mathcal{D}_1 \quad (7)$$

If we assume  $\mathcal{D}_1 = \text{ca. } 10^{-6}$ , which seems reasonable for this type of membrane, then  $d \approx f_w$  microns. From the data presented here we conclude that for such a membrane  $f_w$  is probably not much larger than 0.1 to 0.2. Hence the effective thickness of such a membrane is presumably of the order of 0.1  $\mu$ .

**Acknowledgment.**—We are indebted to Dr. G. Scatchard and Dr. L. Dresner for helpful discussions and to Mr. J. Csurny for valuable technical assistance.

[CONTRIBUTION NO. 859 FROM THE CENTRAL RESEARCH DEPARTMENT, EXPERIMENTAL STATION, E. I. DU PONT DE NEMOURS AND COMPANY, WILMINGTON, DELAWARE]

## Cyanogen Fluoride: Synthesis and Properties<sup>1</sup>

BY F. S. FAWCETT AND R. D. LIPSCOMB

RECEIVED FEBRUARY 14, 1964

Monomeric FCN, b.p.  $-46^\circ$ , has been prepared and isolated and its properties have been investigated. Of several successful high-temperature routes, pyrolysis of cyanuric fluoride at  $1300^\circ$  (50 mm.) is preferred and gives FCN in yields  $>50\%$ .

Although cyanogen fluoride, FCN, has been the subject of a number of investigations,<sup>2</sup> it apparently has not

(1) A preliminary communication of this work has been published: F. S. Fawcett and R. D. Lipscomb, *J. Am. Chem. Soc.*, **82**, 1509 (1960); see also R. D. Lipscomb and W. C. Smith, U. S. Patent 3,008,798 (1961); M. W. Farlow, U. S. Patent 2,980,739 (1961).

(2) (a) V. E. Cosslett, *Z. anorg. allgem. Chem.*, **201**, 75 (1931); (b) H. J. Callomon, H. W. Thompson, F. A. Anderson, and B. Bak, *J. Chem. Soc.*, 3709 (1953); (c) A. A. Woolf, *ibid.*, 252 (1954); (d) E. E. Aynsley, R. E. Dodd, and R. Little, *Proc. Chem. Soc.*, 265 (1959); (e) W. Hüchel, *Nachr. Akad. Wiss. Göttingen*, 36 (1946); *Chem. Abstr.*, **43**, 6793 (1949); (f) O. Ruff, *Ber.*, **69**, 193 (1936); (g) V. Migrdichian, "The Chemistry of Organic Cyano-

previously been isolated, in contrast with the other well-known cyanogen halides. In the present work,<sup>1</sup> it has been found that high-temperature pyrolysis of cyanuric fluoride, (FCN)<sub>3</sub>, under reduced pressure gives high yields of monomeric cyanogen fluoride, b.p.  $-46^\circ$ , which has been isolated in high purity by low-

gen Compounds," Reinhold Publishing Corp., New York, N. Y., 1947, p. 99; (h) R. N. Haszeldine and A. G. Sharpe, "Fluorine and Its Compounds," John Wiley and Sons, Inc., New York, N. Y., 1951, p. 35; (i) A. A. Woolf, *J. Chem. Soc.*, 4121 (1953).

temperature, fractional distillation in dry glass equipment. Cyanogen fluoride was also obtained from several other starting materials by pyrolysis as described briefly below.

**Preparation of FCN.**—The initial experiments that led to the formation of cyanogen fluoride were carried out employing a carbon arc flame as the heat source. Reactants were passed in a carrier gas, usually nitrogen, through a low intensity (50–200 amp., 30–60 v.) rotating arc flame struck between graphite electrodes in a water-cooled reactor, and the exit gases were quenched, collected, and analyzed by mass spectroscopy.

From elemental nitrogen, FCN was formed in extremely low conversions regardless of the fluorine source. Cyanogen, in contrast, reacted with many fluorine-containing compounds to give FCN in good yields. In some systems, higher conversions to FCN were obtained when one or all of the reactants were injected into a hot nitrogen stream (plasma) issuing from the arc. For example, good yields of FCN were obtained when carbon tetrafluoride or carbonyl fluoride was passed through the arc flame and the coreactant cyanogen was injected downstream into the arc plasma. Nitrogen trifluoride, however, fluorinated cyanogen to cyanogen fluoride effectively only when both reactants were injected downstream into a nitrogen arc plasma.

Trifluoroacetonitrile was often found among the pyrolysis products and when this material was fed through the arc flame, it gave a 30% yield of FCN along with tetrafluoroethylene as a coproduct; relatively minor amounts of  $C_2F_6$ ,  $(CN)_2$ , and  $CF_4$  were also obtained. Cyanuric fluoride when passed directly through the arc flame gave FCN in low yield together with  $CF_3CN$ ,  $(CN)_2$ , and major amounts of  $CF_4$  and  $C_2F_4$ . Milder pyrolysis with a partially shielded arc flame gave a 50–60% yield of cyanogen fluoride.

From the above results, it appears that FCN is formed readily as a pyrolysis product, especially if the CN bond already exists in one of the reactants. The very short reaction times and prompt removal of the products from the reaction zone presumably contribute to the survival of FCN.

For a more convenient laboratory preparation of cyanogen fluoride, advantage was taken of the relatively lower pyrolysis temperature of cyanuric fluoride. This readily accessible starting material could be pyrolyzed to cyanogen fluoride in an induction-heated carbon tube reactor (Fig. 1). At temperatures below  $1000^\circ$ , the cyanuric fluoride was recovered with no indication of the formation of FCN, while above  $1300^\circ$  substantially complete conversion occurred under the conditions described in Table I. At  $1700$ – $2000^\circ$ , lower conversions to FCN were obtained, and increased amounts of elemental nitrogen and fluorocarbons, especially  $CF_4$  and  $C_2F_4$ , were formed. Routine preparations were carried out at  $1300$ – $1400^\circ$ . Other coproducts at all temperatures examined were cyanogen and  $CF_3CN$ .

The products observed from cyanuric fluoride can be accounted for plausibly by the following speculative scheme (Scheme I). The products underlined are those actually observed from cyanuric fluoride in both the arc and induction-heated reactors. The arc experiments cited above, in which various materials were

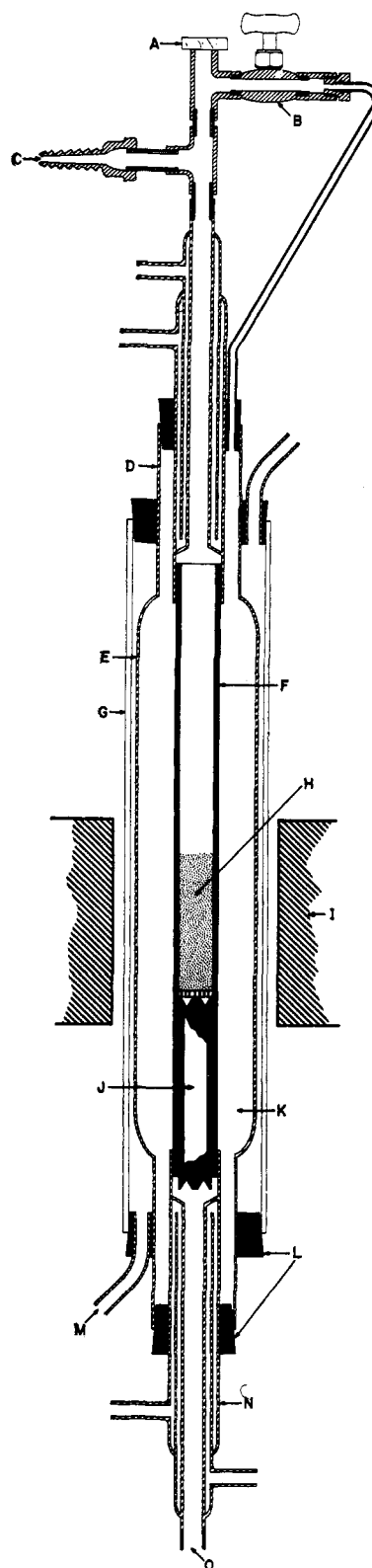

Fig. 1.—A, sight glass; B, needle valve; C, gas inlet; D, 44-mm. o.d. quartz; E, 68-mm. o.d. quartz; F, 1-in. o.d.  $\times$  0.75 in. i.d. "Graphite" tube; G, 80-mm. o.d. Pyrex tube; H, 8–12 mesh graphite; I, induction heating coil *ca.* 3.625 in. i.d.  $\times$  4.5 in. long, internally water cooled; J, hollow carbon tube to support perforated carbon retaining disk; K, powdered graphite insulation; L, rubber stoppers; M, 0.375-in. copper tubing water connections (inlet at bottom); N, water-cooled holders made of concentric pieces of Streamline copper pipe, respectively, 0.5, 0.75, and 1 in. in diameter (nominal size); O, product exit to traps.

TABLE I  
PYROLYSIS OF CYANURIC FLUORIDE TO FCN

Temp., °C. <sup>a</sup>	Exit pressure, mm.	(FCN) <sub>3</sub> , g.	Time, hr.	N <sub>2</sub> , cm. <sup>3</sup> /min.		Approximate conversion to FCN, %
				In	Out	
1050	27	34	1.0	400	400	None detected <sup>b</sup>
1425	60-65	25	0.5	400	410	50-65
1700	25	43	1.0	450	500	45
1700	60-65	26	0.5	450	530	25-50
2000	60-65	24	0.5	450	640	20-25
1400	45	155	3.0	350		45 <sup>c</sup>
1350	45	105	2.0	300		55 <sup>c</sup>
1300	44	225	4.0	350		58 <sup>c</sup>
1300	59	230	4.25	475		60 <sup>c</sup>

<sup>a</sup> Maintained at this value within  $\pm 50^\circ$ . <sup>b</sup> There was recovered 91% of cyanuric fluoride; all other experiments gave essentially complete conversion of cyanuric fluoride. <sup>c</sup> Based on crude FCN fraction, b.p.  $-46$  to  $-40^\circ$ .

used as feed, support Scheme I in showing evidence for the reverse of certain of the reactions written.

SCHEME I

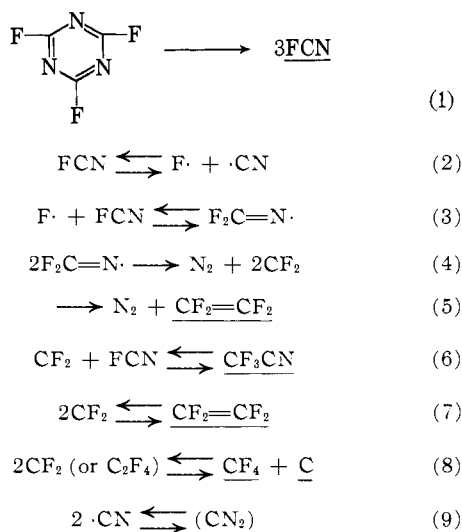

Hexafluoroethane, which was obtained in small amount, may result from dimerization of  $\text{CF}_3\cdot$  produced by cleavage of the carbon-carbon bond of trifluoroacetonitrile or by combination of  $\text{F}\cdot$  with  $\text{CF}_2$ .

**Properties of FCN.**—Monomeric cyanogen fluoride purified by fractional distillation had b.p.  $-46.2^\circ$  and m.p.  $-82^\circ$ . Vapor pressure data and derived constants<sup>3</sup> are summarized in Table II. Elemental fluorine and molecular weight determinations and the mass spectrum (Table III) indicated the structure FCN.

The infrared absorption spectrum of gaseous FCN showed three prominent bands: two doublet bands centered at 2290 ( $\text{C}\equiv\text{N}$ ) and at 1078  $\text{cm}^{-1}$  ( $\text{C}-\text{F}$ ), the latter with 24- $\text{cm}^{-1}$  separation between the two branches, and a triplet band centered at 451  $\text{cm}^{-1}$ . The positions of these bands correspond closely with those calculated by Thomas<sup>4</sup> and by Luft<sup>5</sup> and also with

(3) We are grateful to Dr. N. E. Miller of this laboratory who carried out the vapor pressure measurements.

(4) W. J. O. Thomas, *J. Chem. Phys.*, **20**, 920 (1952).

(5) N. W. Luft, *ibid.*, **21**, 1900 (1953).

TABLE II  
VAPOR PRESSURE<sup>a</sup> OF FCN

Temp., °C.	Solid		Temp., °C.	Liquid	
	Pressure, mm.— Obsd.	Calcd. <sup>b</sup>		Pressure, mm.— Obsd.	Calcd. <sup>c</sup>
-126.3	0.3	0.3	-76.4	120.1	123.3
-116.7	1.4	1.4	-75.0	136.1	135.5
-106.7	5.4	5.5	-72.5	160.7	160.5
-104.7	7.3	7.1	-71.5	168.7	171.7
-100.6	11.1	11.5	-66.9	232	231
-100.0	12.3	12.3	-64.0	278	277
-95.6	18.9	20.0	-57.3	414	412
-92.3	28.9	28.3	-52.9	528	529
-91.8	29.4	30.4	-51.3	578	578
-92.1	30.1	29.5	-50.0	621	620
-88.9	41.2	41.1	-49.0	649	652
-86.7	50.4	51.6	-47.9	692	694
-86.3	53.9	53.7	-46.8	731	734
-82.6	77.3	77.4			

<sup>a</sup> See ref. 3. <sup>b</sup>  $\log p$  (mm.) =  $-1508.0/T + 9.798$ . <sup>c</sup>  $\log p$  (mm.) =  $-1169.2/T + 8.030$ . The boiling point is  $-46.2^\circ$ , f.p.  $-82^\circ$ , Trouton's constant = 23.6,  $\Delta H_v = 5.35$  kcal./mole,  $\Delta H_s = 6.90$  kcal./mole;  $\Delta H_f = 1.5$  kcal./mole.

TABLE III

FRAGMENTATION PATTERN OF FCN

m/e	Ion	Pattern, %
12	$\text{C}^+$	11.47
14	$\text{N}^+$	4.13
19	$\text{F}^+$	1.06
26	$\text{CN}^+$	17.71
31	$\text{CF}^+$	15.29
45	$\text{FCN}^+$	100.0

those observed by Aynsley, Dodd, and Little,<sup>2d</sup> and by Dodd and Little,<sup>6</sup> which were observed for a mixture obtained by fluorination of cyanogen.

The fluorine n.m.r. pattern showed a triplet peak that centered at 80 p.p.m. to high field of  $\text{CF}_3\text{CO}_2\text{H}$  with 32-35 c.p.s. splitting between adjacent peaks. The splitting, attributed to the  $\text{N}^{14}$  nucleus, collapsed to a singlet peak on cooling to near the freezing point. This temperature dependence of the  $\text{F}^{19}$  multiplet structure of FCN is similar to that<sup>7</sup> observed for  $\text{NF}_3$  and is attributed to the temperature dependence of the quadrupole-dominated relaxation time of the  $\text{N}^{14}$  nucleus.<sup>8</sup> Microwave spectral data for FCN have been reported.<sup>9</sup>

At room temperature, liquid cyanogen fluoride is converted rapidly to polymeric materials, including cyanuric fluoride and a high-melting, water-sensitive solid polymer, but in the gas phase at atmospheric pressure it has been recovered partially after several weeks. Tests for explosiveness<sup>10</sup> showed that liquid FCN at  $-41^\circ$  exploded when initiated by a squib, developing greater pressure than would be obtained with acetylene under similar conditions. Gaseous FCN at 1 atm. and room temperature was not ignited by a spark or by a hot wire. Cyanogen fluoride-air mix-

(6) R. E. Dodd and R. Little, *Spectrochim. Acta*, **16**, 1083 (1960).

(7) E. L. Muettterties and W. D. Phillips, *J. Am. Chem. Soc.*, **81**, 1084 (1959). We are indebted to Dr. W. D. Phillips for the interpretation of the n.m.r. data.

(8) J. A. Pople, *Mol. Phys.*, **1**, 168 (1958).

(9) J. Sheridan, J. K. Tyler, F. E. Aynsley, R. E. Dodd, and R. Little, *Nature*, **185**, 96 (1960).

(10) We are indebted to Mr. H. W. Whitmeyer of Explosives Department, E. I. du Pont de Nemours and Co., for these tests.

tures, however, were found more susceptible to ignition than pure FCN and showed greater explosive potential than acetylene-air mixtures.

In view of the potentially hazardous nature of FCN, all experiments with it were carried out with safety precautions. It has been regarded as a toxic material. In two instances, contacting liquid FCN at near  $-80^{\circ}$  with small quantities of either HF or  $\text{BF}_3$  has resulted in violent decomposition with bursting of the safety rupture assembly of the barricaded metal pressure equipment. No serious difficulty was experienced, however, in the course of working with a total of several hundred grams of cyanogen fluoride.

### Experimental

**Cyanuric Fluoride,  $(\text{FCN})_3$ .**—Cyanuric fluoride (2,4,6-trifluoro-1,3,5-triazine) was prepared from cyanuric chloride and sodium fluoride in tetramethylene sulfone medium by the procedure of Tullock and Coffman.<sup>11</sup>

**Pyrolysis.**—Accessory equipment consisted of: a, a stainless steel cylinder in a water bath at  $60^{\circ}$ , fitted with a needle valve and flow meter and containing cyanuric fluoride under autogenous pressure; b, a source of nitrogen with similar flow control; c, open-end mercury-in-glass manometers for measuring pressure upstream and downstream from the reactor; d, a glass trap attached to the exit end of the reactor with provisions for cooling with liquid nitrogen; and e, additional traps, a pressure control device, and a high-capacity oil vacuum pump exiting through a trap to a wet test meter.

The reactor<sup>12</sup> (Fig. 1) consisted of a vertically mounted 0.75-in. i.d. "Graphitite"<sup>13</sup> tube (F) packed for a 3-in. length with 4–8 mesh graphite granules (H) and surrounded by graphite powder insulation (K) and a water-jacketed shell (E and G). The tube was heated over a length of approximately 3 to 5 in. by means of an induction heating unit consisting of a water-cooled copper coil (I) surrounding the reactor and a power source (Ajax Electrothermic Corp., Ajax-Northrup mercury hydrogen spark gap high frequency converter, specification No. J254920). Temperatures were measured by sighting the top of the carbon bed through sight glass A with a Leeds and Northrup optical pyrometer, Catalog No. 8622-C.

The apparatus was assembled using 0.375-in. copper tubing except for glass flow meters, manometers, etc., the connections being made with 0.25-in. i.d.  $\times$  0.125-in. wall thickness butyl rubber tubing. Prior to a run, the entire system with valve B (Fig. 1) open was evacuated to ca. 0.3 mm. and pressure tested. The furnace was then brought to operating temperature, the traps were cooled, and the system brought to the operating pressure with nitrogen adjusted to the desired flow rate. Valve B was then closed to isolate the graphite insulation (K) from the process stream, and the run was begun by adjusting the valve of the cyanuric fluoride storage cylinder. Operating pressure measured downstream from a trap at the exit (lower) end of the reactor was controlled by balancing flow rates and pumping rate.

**Isolation of FCN.**—The total pyrolysate was collected as a fluffy white solid in liquid nitrogen-cooled traps. At the end of a run, the traps were isolated from the reactor and were filled to atmospheric pressure with nitrogen or helium. At atmospheric pressure, the crude product was allowed to vaporize without ap-

plication of heat into traps cooled with solid carbon dioxide-acetone. The bulk of the FCN was retained in these traps while lower boiling impurities, such as  $\text{CF}_4$ ,  $\text{C}_2\text{F}_4$ , and some of the  $\text{CF}_3\text{-CN}$  passed through uncondensed. Distillation of the contents of the solid carbon dioxide-cooled traps through a dry glass, low-temperature, Heli-Pak fractionating column gave FCN, b.p.  $-46^{\circ}$ , as a colorless liquid after a forerun of  $\text{CF}_3\text{CN}$ , b.p.  $-62^{\circ}$ . The progress of the fractionation could be followed by periodic gas chromatographic examination<sup>14</sup> of samples collected from the vapor stream. The distilled FCN was transferred *in vacuo* to a previously evacuated stainless steel cylinder equipped with a rupture disk assembly and was stored under autogenous pressure at  $-78^{\circ}$ .

*Anal.* Calcd. for FCN: F, 42.21; mol. wt., 45.02. Found: F, 42.32, 42.39; mol. wt., 45.1 (gas density).

The mass spectrum shown in Table III was obtained with a Consolidated Electroynamics Corp. Model 21-103-C spectrometer. Infrared data were obtained by Miss Naomi Schlichter with a Perkin-Elmer Model 21 double-beam spectrometer (doublet bands) or a Perkin-Elmer Infracord instrument equipped with potassium bromide prisms (triplet band). The n.m.r. measurement was made with a Varian high resolution spectrometer at 40 Mc. on a sample sealed in a heavy-walled glass capillary tube. The vapor pressure data in Table II<sup>3</sup> were obtained on a center cut of fractionated FCN using an isoteniscope with a mercury manometer and manually stirred liquid cooling bath. Pressures were measured from 0.05 to 0.1 mm. with a cathetometer and corrected to  $0^{\circ}$ . Temperatures were measured with a calibrated (National Bureau of Standards) copper-constantan thermocouple using a  $0^{\circ}$  reference junction and a Leeds and Northrup Type K-2 potentiometer. Reproducibility of the pressure readings on successive days, e.g., the low pressure values even after warming to near the normal boiling point, indicated that the sample was stable during the measurements. The data were divided roughly into  $5^{\circ}$  temperature intervals and the average for each interval was obtained by averaging the  $\log p$  and  $1/T$  values of the experimental points. The linear equations fitting these average values were determined by graphical and least-squares methods. The melting point was determined from the intersection of the vapor pressure curves for the solid and the liquid.

Gas phase storage stability was observed by placing a sample initially containing ca. 95% FCN (mass spectroscopy) in a glass vessel at room temperature and atmospheric pressure. After a period of 3 weeks, the material was found to contain ca. 90% FCN and ca. 3% cyanuric fluoride. In the liquid phase, an 18-g. sample of FCN in a 125-ml. "Hastelloy C"-lined pressure vessel, when warmed to  $17^{\circ}$ , showed a pressure of 180 p.s.i.; 3 hr. later at  $29^{\circ}$  it showed 50 p.s.i., and after another 3 hr. at  $29^{\circ}$  the pressure was 20 p.s.i. The resulting viscous yellow sirup on dilution with ether gave a white solid polymer, which reacted with water to form an acidic solution that contained fluoride ion. The ether-soluble portion was found to contain  $(\text{FCN})_3$ .

FCN has been stored without appreciable change for over 1 year in stainless steel cylinders kept at solid carbon dioxide temperature.

**Acknowledgment.**—We are indebted to Drs. J. E. Castle, D. D. Coffman, W. C. Smith, and the late M. W. Farlow for helpful discussions and suggestions during this investigation.

(14) A column packed with D. C. Silicone 200 oil on firebrick was used. At room temperature, peaks corresponding to  $\text{CF}_3\text{CN}$  and to  $(\text{CN})_2$  were observed along with a large peak intermediate between these two that was attributed to FCN. In addition, a long low peak appeared much later. With a column temperature of  $0^{\circ}$ , the latter peak was essentially eliminated and the FCN peak was increased in size. It appeared that during passage through the column at room temperature, but not at  $0^{\circ}$ , part of the FCN was converted to some unidentified material. We are indebted to Dr. E. K. Ellingboe for providing advice and equipment for the chromatography experiments.

(11) C. W. Tullock and D. D. Coffman, *J. Org. Chem.*, **25**, 2016 (1960).

(12) The reactor was designed by the late Dr. M. W. Farlow of this laboratory, who provided it for use in this work.

(13) Impermeable graphite pipe, type A, of Graphite Specialties Corp., Niagara Falls, N. Y.